

**1 Pantelimon St., District 2  
CP 021591 -Bucharest-ROMANIA  
Tel ++40 21 252 14 50  
252 78 81  
Fax ++40 21 252 20 57  
Web site : [www.diateh-romania.ro](http://www.diateh-romania.ro)  
EMail : [diateh@diateh-romania.ro](mailto:diateh@diateh-romania.ro)**



# Manufacturing programme

According to our technical documentation's or upon a customer's request.

## **SUPERABRASIVE POWDERS:**

- synthetic diamond, cubic boron nitride

**BOND** : resin

## **INDUSTRIAL APPLICATIONS**

- cutting of : concrete , refractory, marble , granite , a.s.o.
- materials processing such us : sintered carbide tips, high thermic treated steel with hardness over 45 HRC

## **SUPERABRASIVE TOOLS**

- wheels
- rods
- rolls

**We offer immediately modern and efficient solutions !**



# Our offer

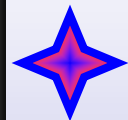
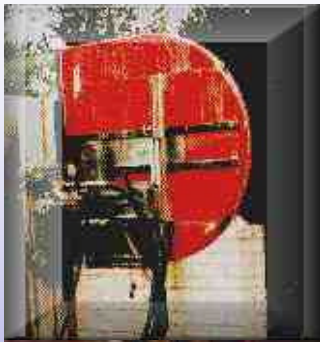

**Diamond tools for building materials processing**

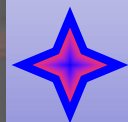

**Extrahard materials tools for grinding and sharpening**

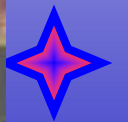

**Special diamond or cubic boron nitride grinding wheels with resin bond**

# Diamond tools for building materials processing

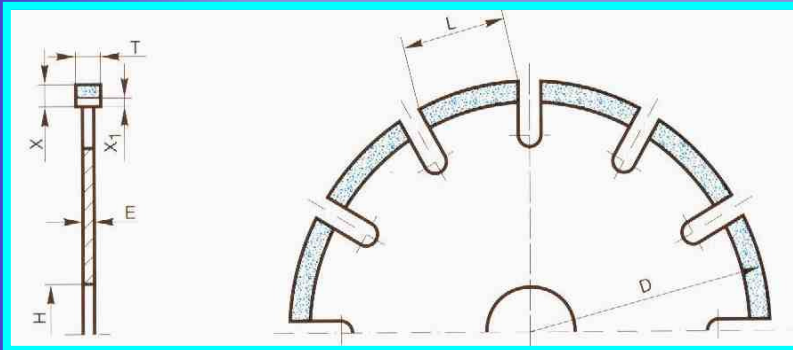

1A1RSS/C1

(1)

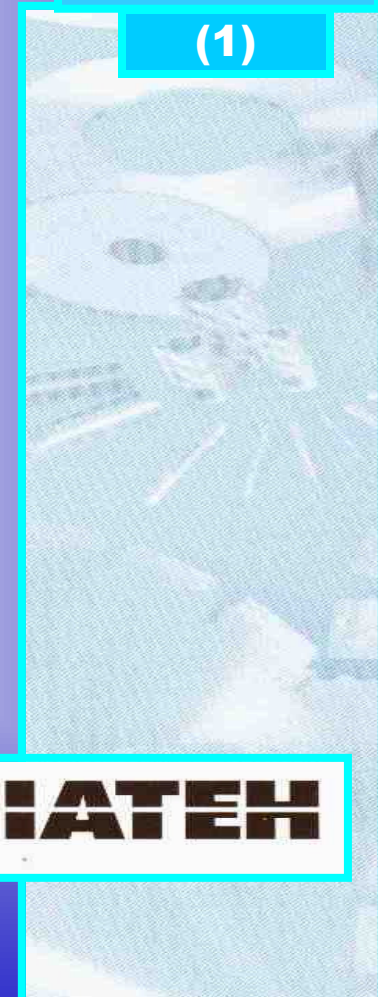

D	E	H	No. segments	L	T	X					X1*
						5	7	8	10	12	
200	1.2	40	12	40	1.7/2.0	x	x				
250	1.6	40	15	40	2.0/2.4	x	x				
300	1.8	40	18	40	2.4/2.8	x	x		x		
350	2.2	60	21	40	2.8/3.2	x	x		x		
400	2.5	60	24	40	3.2/3.6	x	x		x	2 - 4	
450	2.8	60	26	40	3.6/4.5	x	x		x	mm	
500	2.8	60	30	40	4.5/5.0	x	x		x		
550	3.5	60	32	40	3.6/4.5	x	x		x		
600	3.5	60	36	40	5.0/5.5	x	x		x		
625	3.5	60	36	40	5.0/5.5	x	x		x		
700	4.0	80	40	40	5.5/6.5	x	x		x		
800	4.5	80	46	40	5.5/6.5	x	x		x		

X1 \* - by special request

Example of order

Type            D - H            No. segments    L- T - X            Concentration    Materials  
 1A1RSS/C1    200 - 40            12            40-2.0-5            45.5%            marble



# Diamond tools for building materials processing

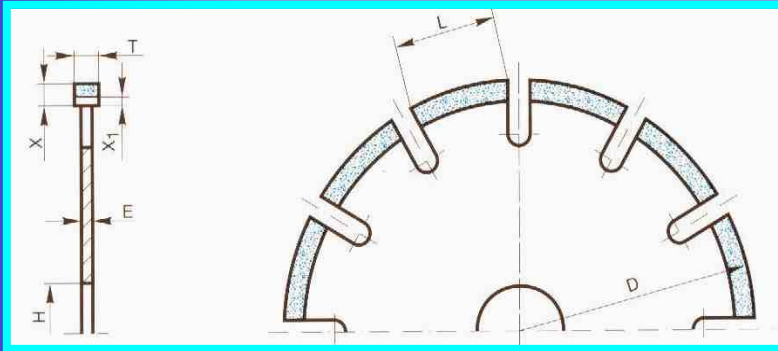

1A1RSS/C1

(2)

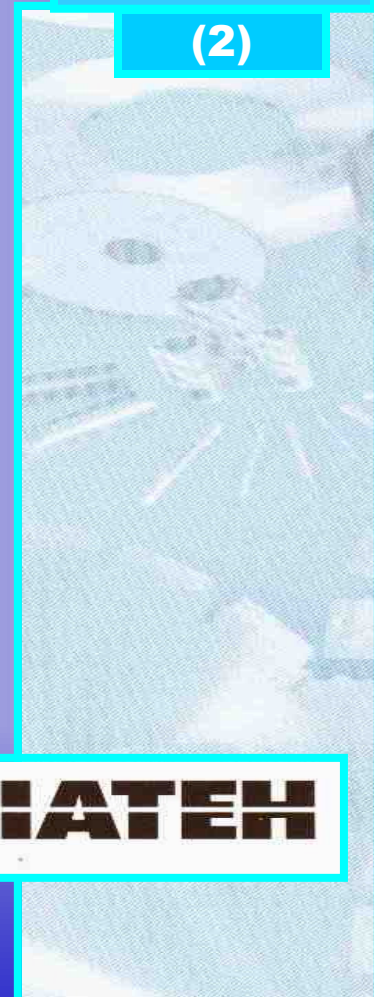

D	E	H	No. segments	L	T	X					X1*	
						5	7	8	10	12		
900	5.0	100	64	24	6.5/ 7.5				x	x	x	
1000	5.0	100	64	24	7.0/ 7.5				x	x	x	
1100	5.0	100	74	24	7.0/ 7.5				x	x	x	
1200	5.5	100	80	24	7.5/ 8.0					x	x	
1100	5.0	100	74	24	7.0/ 7.5					x	x	
1350	6.0	150	88	24	9.0/10.5					x	x	
1500	7.0	150	100	24	9.0/ 9.0					x	x	
1500	7.0	150	100	24	9.0/ 9.0					x	x	
1600	7.0	150	108	24	9.0/10.5					x	x	
1800	7.0	150	120	24	10.5/10.5					x	x	
2000	8.0	150	132	24	10.5/10.5					x	x	
2500	9.0	140	140	24	12.0/13.0					x	x	
2700	9.0	150	140	24	12.0/13.0					x	x	

X1 \* : 2 - 4 mm

Example of order

Type 1A1RSS/C1    D - H 200 - 40    No. segments 12    L- T - X 40-2.0-5    Concentration 45.5%    Materials marble



# Diamond tools for building materials processing

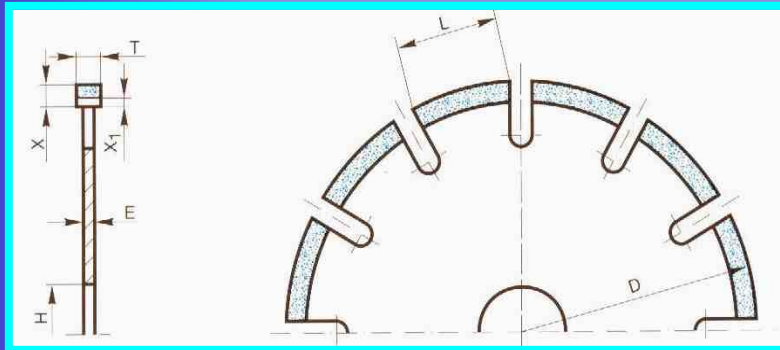

1A1RSS/C2

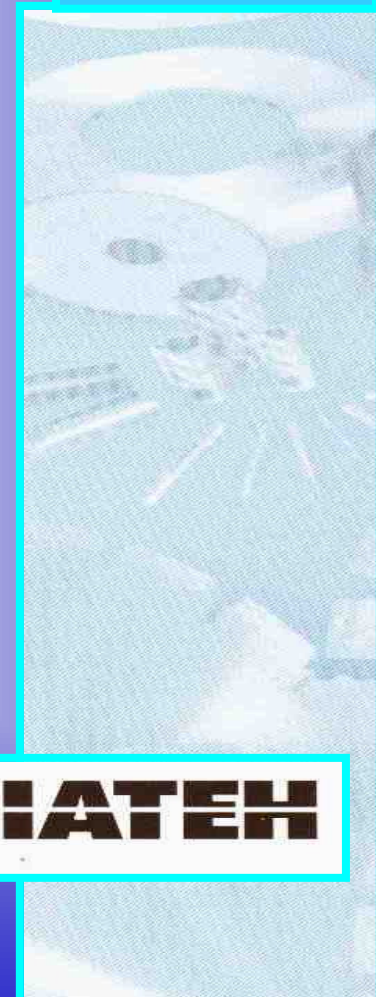

D	E	H	No. segments	L	T	X			X1*
						5	7	10	
200	1.2	40	13	40	1.7/2.0	x	x		
250	1.6	40	17	40	2.0/2.4	x	x		
300	1.8	40	21	40	2.4/2.8	x	x	x	
350	2.2	60	25	40	2.8/3.2	x	x	x	
400	2.5	60	28	40	3.2/3.6	x	x	x	
450	2.8	60	32	40	3.6/4.5	x	x	x	
500	2.8	60	36	40	4.5/5.0	x	x	x	
550	3.5	60	40	40	3.6/4.5	x	x	x	
600	3.5	60	42	40	5.0/5.5	x	x	x	
625	3.5	60	42	40	5.0/5.5	x	x	x	
700	4.0	60	50	40	5.5/6.5	x	x	x	
800	4.5	60	57	40	5.5/6.5	x	x	x	

X1 \* - by special request

Example of order



Type	D - H	No. segments	L- T - X	Concentration	Materials
1A1RSS/C2	200 - 40	13	40-2.0-5	45.5%	marble

# Extrahard materials tools for grinding and sharpening

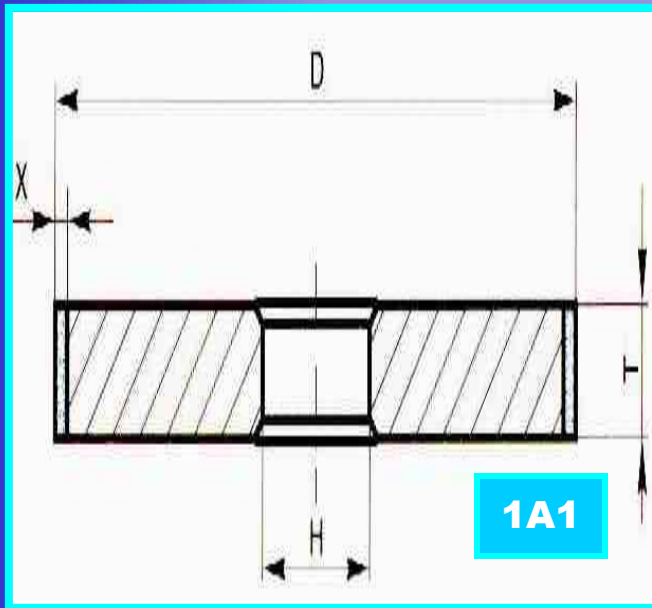

1A1

D	T	X	H*	D	T	X	H*
20	6			200	6		
20	10			200	10		
25	6			200	15		
25	10			200	20		
30	6			250	6		
30	10			250	10		
40	6			250	15		
40	10			250	20		
50	6			250	30		
50	8			250	40		
50	10			250	60		
75	6			300	10		
75	8			300	15		
75	10			300	20		
100	6			300	40		
100	8			300	60		
100	10			350	10		
100	12			350	20		
125	6	350	30				
125	8	400	20				
125	10	400	40				
125	12	400	60				
125	15	H* - by request					
150	6	•	, resin bond				
150	8						
150	10						
150	15						
150	20						
175	6						
175	10						
175	15						
175	20						

## Example of order

Type D - T - X - H  
 1A1 150 - 6 - 2 - 20

Grain size D 64  
 Bond R  
 Concentration 100

1A1



# Extrahard materials tools for grinding and sharpening

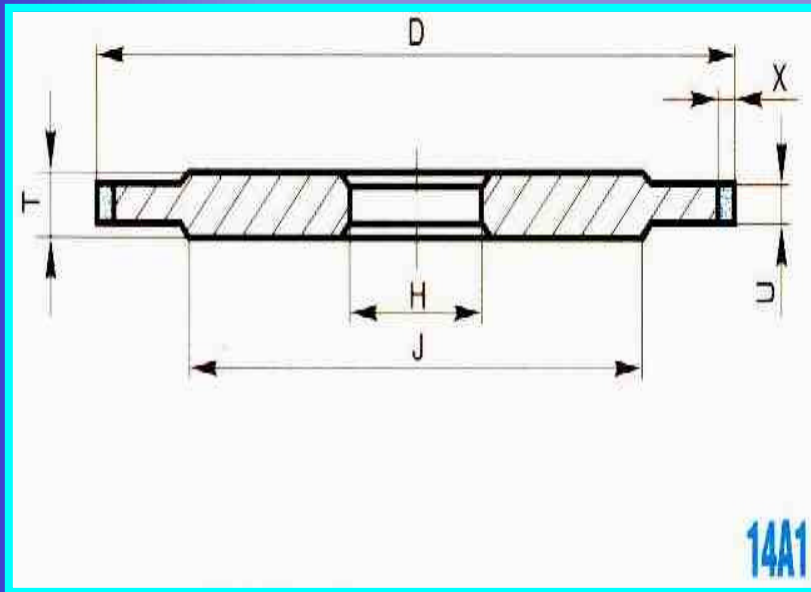

D	U	X	H*	T	J
175	2	3;4		8	140
175	3	3;4			140
175	4	3;4		8	140
175	5	3;4			140
200	2	3;4;5		10	160
200	3	3;4;5			160
200	4	3;4;5		10	160
200	5	3;4;5			160
200	6	3;4;5		10	160
250	6	3;4;5			200
250	10	3;4;5		16	200
300	10	3;4			240
350	10	3;4			280
400	10	3;4			320

14A1



D	U	X	H*	T	J
75	2	3;4;5			50
75	3	3;4;5		6	50
75	4	3;4;5			50
100	2	3;4;5		6	70
100	3	3;4;5			70
100	4	3;4;5		6	70
100	5	3;4;5			70
125	2	3;4		6	100
125	3	3;4			100
125	4	3;4		6	100
125	5	3;4			100
150	2	3;4;5		8	120
150	3	3;4;5			120
150	4	3;4;5		8	120
150	5	3;4;5			120

• resin bond

H\* - by request

Example of order

Type            D - U - X - H  
 14A1            200 - 4 - 3 - 20

Grain size    Bond            Concentration  
 D 64            R                    100





# Extrahard materials tools for grinding and sharpening

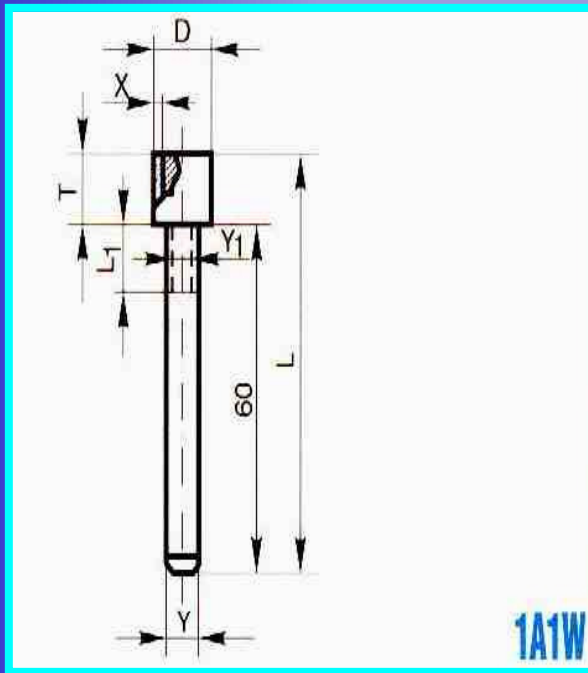

D	T	X	RB*	Y	Y1	L	L1
6	6	1.5		6	3	66	8
6	6	1.5		6	3	68	10
7	6	2		6	3	66	8
7	8	2		6	3	68	10
8	6	2		6	4	66	8
8	10	2		6	4	70	12
9	6	2		6	5	66	8
10	6	2		6	-	66	-
10	10	2		6	-	70	-
12	6	2		6	-	66	-
12	12	2		6	-	72	-
14	6	2		6	-	66	-
15	6	2		6	-	66	-
15	15	2		6	-	75	-
16	6	2		6	-	66	-
18	6	2		6	-	66	-
20	6	2		6	-	66	-
24	6	2		6	-	66	-

RB\* - resin bond

Example of order

Type D - T - X  
1A1W 8 - 6 - 2

Grain size Bond Concentration  
D 64 R 100

1A1W



# Extrahard materials tools for grinding and sharpening

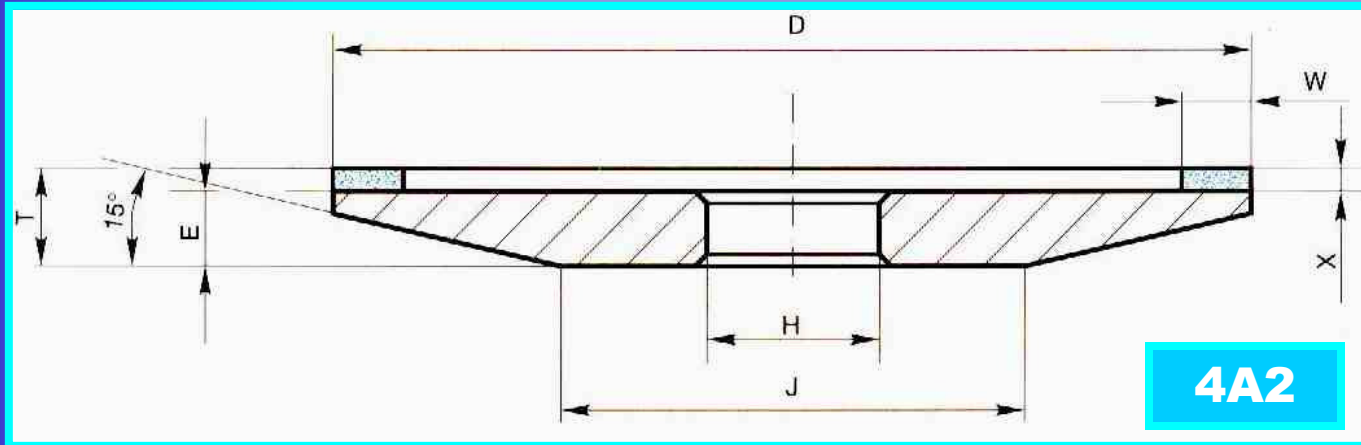

4A2



Example of order

Type D - W - X - H  
4A2 75 - 6 - 3 - 20

Grain size Bond Concentration  
D 64 R 100

H\* - by request  
•resin bond

D	W	X	H*	T-X=E	J
75	3			6	41
75	6			6	41
75	10			6	41
100	3			6	66
100	6			6	66
100	10			6	66
125	4			7	83
125	6			7	83
125	8	2 ;		7	83
125	10	3 ;		7	83
150	4	4		9	94
150	6			9	94
150	8			9	94
150	10			9	94
175	6			10	111
175	8			10	111
175	10			10	111
200	6			15	99
200	8			15	99
200	10			15	99



# Extrahard materials tools for grinding and sharpening

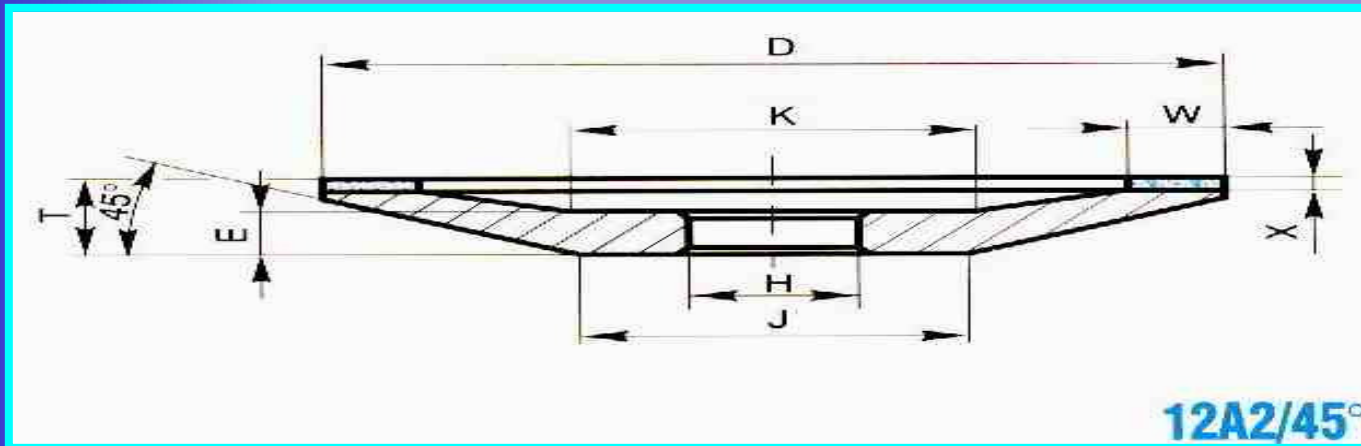

12A2/45°

12A2/45°

Example of order

Type D - W - X - H  
12A2/45° 75 - 3 - 2 - 20

Grain size Bond Concentration  
D 91 R 100

H\* - by request

• resin bond

D	W	X	H*	T-X	E	K	J
75	3			6	10	49	37
75	6			6	10	45	37
75	10			6	10	43	37
100	3			22	10	70	58
100	6			22	10	64	58
100	8			22	10	60	58
100	10			22	10	56	58
100	15			22	10	46	58
125	4	2;		22	10	93	83
125	6	3;		22	10	89	83
125	8	4		22	10	85	83
125	10			22	10	81	83
125	12.5			22	10	76	83
125	15			22	10	71	83
150	4			22	12	122	108
150	6			22	12	118	108
150	10			22	12	105	108
150	12.5			22	12	105	108
150	15			22	12	100	108



# Extrahard materials tools for grinding and sharpening

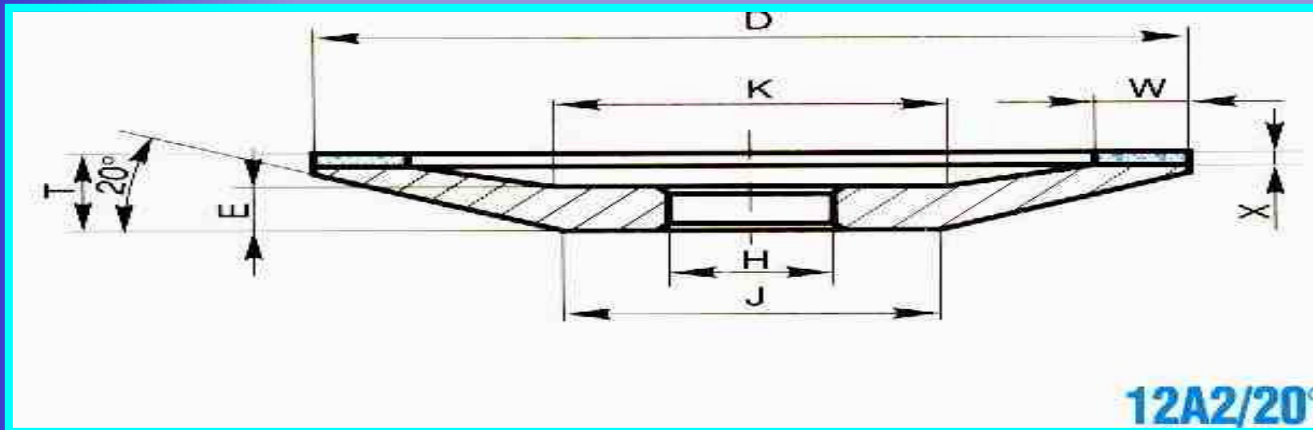

12A2/20°

12A2/20°

D	W	X	H*	T-X	E	K	J
50	6			8	6	23	25
75	3			8	6	54	34
75	6			8	6	48	34
75	10			8	6	40	34
100	3			10	8	79	48
100	6			10	8	73	48
100	8			10	8	69	48
100	10	2 ;		10	8	65	48
125	4	3 ;		14	8	72	51
125	6	4		14	8	68	51
125	8			14	8	64	51
125	10			14	8	60	51
125	12.5			14	8	65	51
150	4			16	9	90	65
150	6			16	9	90	65
150	10			16	9	90	65
150	12.5			16	9	90	65
150	15			16	9	90	65

D	W	X	H*	T-X	E	K	J
175	6			18	10	103	79
175	10			18	10	95	79
175	15	2 ;		18	10	85	79
200	6	3 ;		20	12	128	93
200	10	4		20	12	120	93
200	15			20	12	110	96
250	6			23	13	163	123
250	10			23	13	155	126
250	15			23	13	145	126

• resin bond

H\* - by request

Example of order

Type D - W - X - H

12A2/20° 200- 6 - 2 - 20

Grain size Bond Concentration

D 64 R 100



# Extrahard materials tools for grinding and sharpening

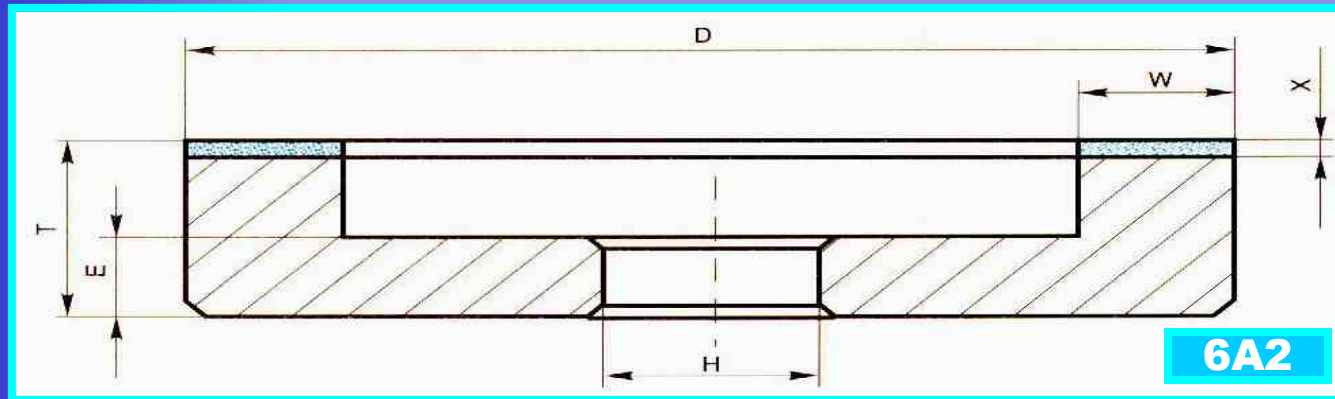

6A2

6A2

D	W	X	H*	T-X	E	D	W	X	H*	T-X	E
50	6			20	10	150	20			22	10
75	3			20	10	150	25			22	10
75	6			20	10	150	30			22	10
75	10			20	10	175	6			23	13
100	4			22	10	175	10			23	13
100	6			22	10	175	15			23	13
100	8			22	10	175	20			23	13
100	10			22	10	175	25			23	13
100	15	2; 3; 4		22	10	200	10	2; 3; 4		23	13
125	4			22	10	200	15			23	13
125	6			22	10	200	20			23	13
125	8			22	10	200	25			23	13
125	10			22	10	250	10			23	13
125	12			22	10	250	15			23	13
125	15			22	10	250	20			23	13
125	30			22	10	300	10				
150	4			22	10	300	20				
150	6			22	10	350	12				
150	10			22	10	350	25				
150	12.5			22	10						
150	15			22	10						

Example of order

Type            D - W - X - H  
**6A2**            **175 - 40 - 2 - 20**

Grain size    Bond    Concentration  
**D 64**            **R**            **100**

RB\*

H\* - by request  
 RB\* - resin bond



# Extrahard materials tools for grinding and sharpening

D	W	X	H*	T	E
100	6			22	10
100	8			22	10
100	10			22	10
125	6			22	10
125	8			22	10
125	10			22	10
150	6			25	14
150	8	2; 3;		25	14
150	10			25	14
150	15			25	14
175	6			25	14
175	8			25	14
175	10			25	14
175	15			25	14
200	8			30	18
200	10			30	18
200	15			30	18

H\* -,by request  
- resin bond

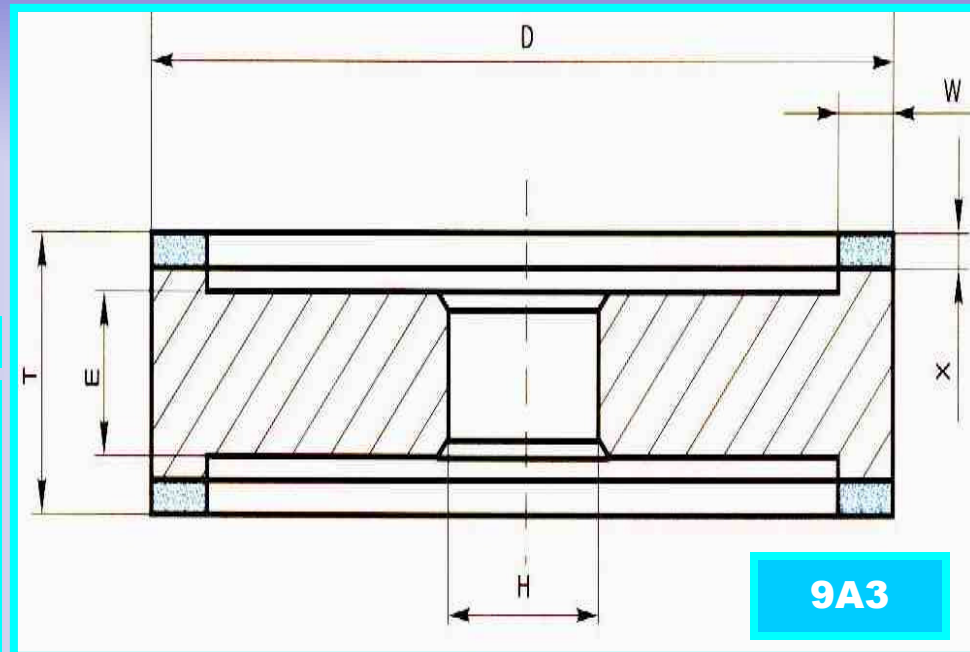

9A3

9A3

## Example of order

Type            D - W - X - H  
 9A3            175 - 6 - 2 - 20

Grain size    Bond    Concentration  
 D 64            R            100



# Extrahard materials tools for grinding and sharpening

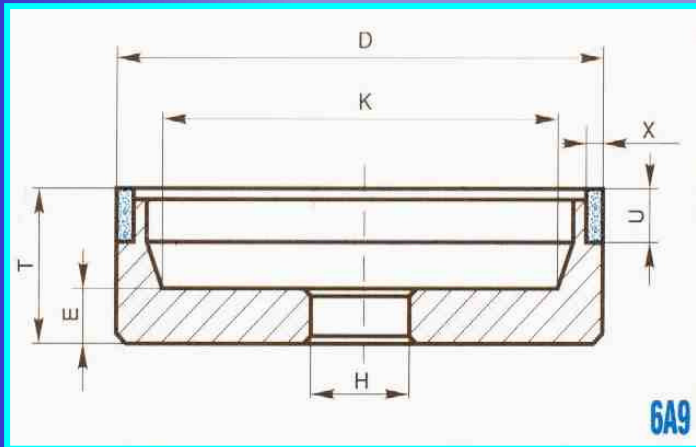

6A9

Example of order

Tip

Type D - X - U - H  
6A9 125 - 2 - 6 - 20

Grain size  
D 91

Bond R Concentration 100

D	X	U	H*	T	E	K
75	2	2		25	10	60
75	3			25	10	60
100	2			30	10	80
100	3			30	10	80
125	2			30	10	107
125	3			30	10	107
150	2			35	10	132
150	2			35	10	132

H\* -by request

•resin bond

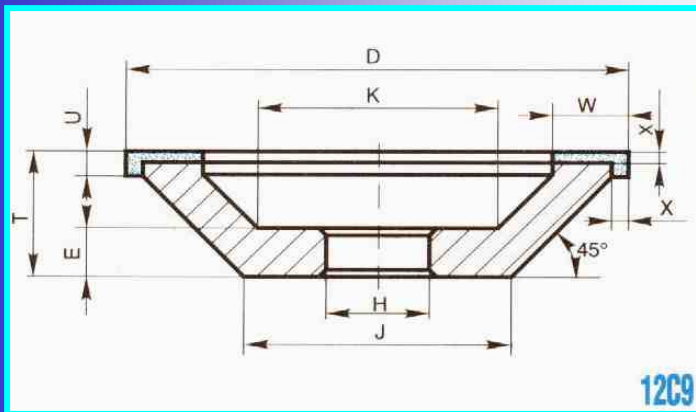

12C9

Example of order

Type D -W- X - U - H  
12C9 100- 10 -2 - 4 -20

Grain size  
D 91

Bond R Concentration 100

D	W	X	U	H*	T	E	K	J
75	6	2			22	10	45	35
75	10			4	22	10	37	35
100	6			4	24	10	66	56
100	10			4	24	10	58	56
125	6			4	24	10	91	81
125	10			4	24	10	83	81
125	10			7.5	24	10	83	88
150	6			4	24	12	120	106
150	10			4	24	12	112	106
150	15			5	24	12	102	108

•resin bond

H\* -by request



# Extrahard materials tools for grinding and sharpening

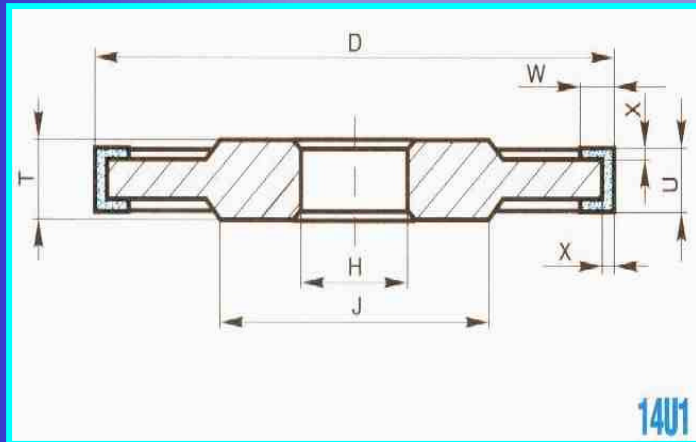

D	W	X	U	H*	T	J
100	6	2	6	on request	8	50
100	10		10		12	50
125	6	2	6	on request	8	65
125	10		10		12	65
150	6	2	6	on request	8	80
150	10		10		12	80
200	6	2	6	on request	8	130
200	10		10		12	130

H\* - on request

• resin bond

**14U1**  
**1L1**

Example of order

Type **D - W - X - U - H** Grain size **D 64** Bond **R** Concentration **100**  
**14U1 200 - 6 - 2 - 6 - 20 D 64 R 100**

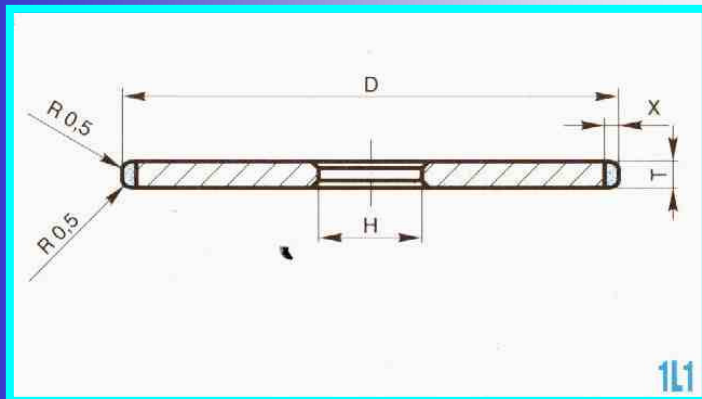

D	T	X	H*
75	3	2;3	on request
74	4		
75	5		
100	3		
100	4		
100	5		
125	3		
125	4		
125	5		
125	6		
150	3	on request	
150	4		
150	5		
150	6	on request	

• liant rezinoid, resin bond

H\* - conform comanda, by request

**Granulatie** **Liant** **Concentratie**  
 Grain size **Bond** **Concentration**  
**D 64** **R** **100**

Exemplu de comanda  
Example of order

Tip **D - T - X - H**  
Type **1L1 75 - 4 2 - 20**





# Scule cu materiale extradure pentru rectificat si ascutit

## Extrahard materials tools for grinding and sharpening

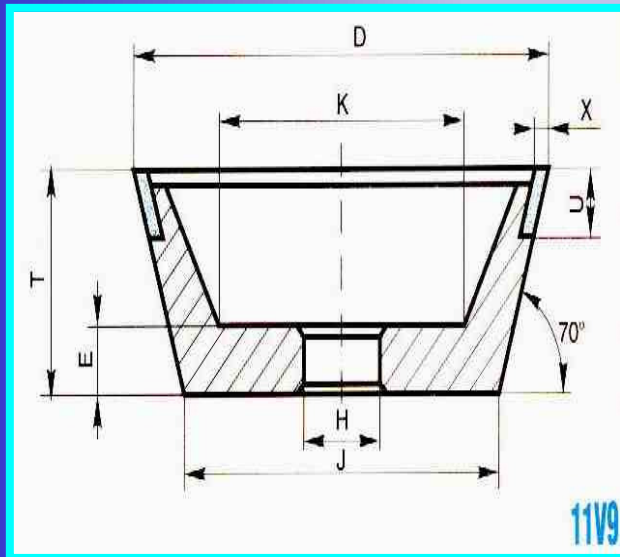

D	X	U	H*	T	E	K	J
50	2	6 ;10		30	10	23	28
75	2	6 ;10		30	10	40	53
75	3	6 ;10		30	10	40	53
100	2	6 ;10		35	10	55	75
100	3	6 ;10		35	10	55	75
125	2	6 ;10		40	10	75	96
125	3	6 ;10		40	10	75	96
150	2	6 ;10		50	10	90	114
150	3	6 ;10		50	10	90	114

•resin bond  
H\* - by request

**11V9**



### Example of order

Type     D - X - U - H  
11V9   100 - 2 - 6 - 20

Grain size   Bond   Concentration  
D 91         R         100



# Extrahard materials tools for grinding and sharpening

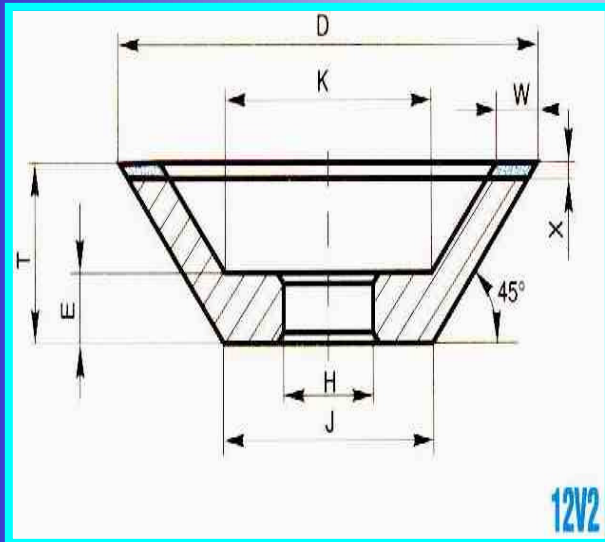

D	W	X	RB*	H*	T	E	K	J
75	6	2; 3; 4			20	10	43	35
100	6				25	10	58	50
100	10				25	10	50	50
125	6				25	10	83	75
125	8				25	10	79	75
125	10				25	10	75	75
150	6				25	12	108	100
150	10				25	12	100	100

RB\* resin bond  
H\* by request

**12V2**



## Example of order

Type D - W - X - H  
12V2 100 - 6 - 2 - 20

Grain size Bond Concentration  
D 64 R 100



# Extrahard materials tools for grinding and sharpening

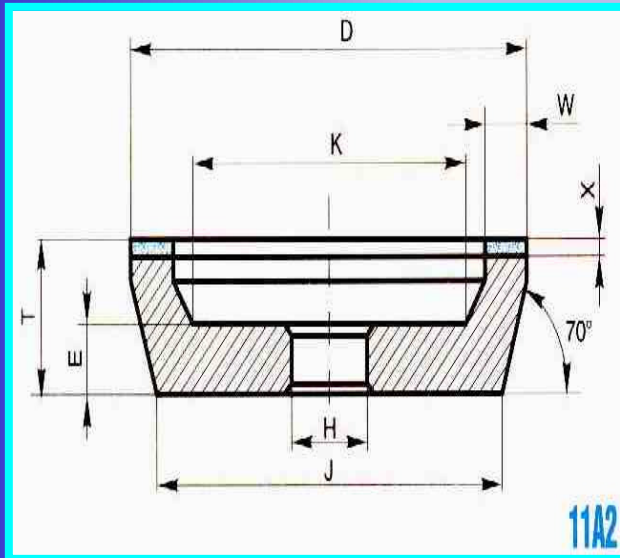

D	W	X	RB*	H*	T	E	K	J
50	6				20	10	30	36
75	3				20	10	61	61
75	6				20	10	55	61
75	10				20	10	47	61
100	3				20	10	86	86
100	6				20	10	80	86
100	8				20	10	76	86
100	10				20	10	72	86
125	4	2;			22	10	108	110
125	6	3;			22	10	104	110
125	8	4			22	10	100	110
125	10				22	10	96	110
125	12.5				22	10	90	110
150	4				22	10	133	135
150	6				22	10	129	135
150	10				22	10	121	135
150	15				22	10	111	135

RB\* - resin bond

H\* - by request

Example of order

Type D - W - X - H  
11A2 75 - 6 - 2 - 20

Grain size Bond Concentration  
D 64 R 100

11A2



# Extrahard materials tools for grinding and sharpening

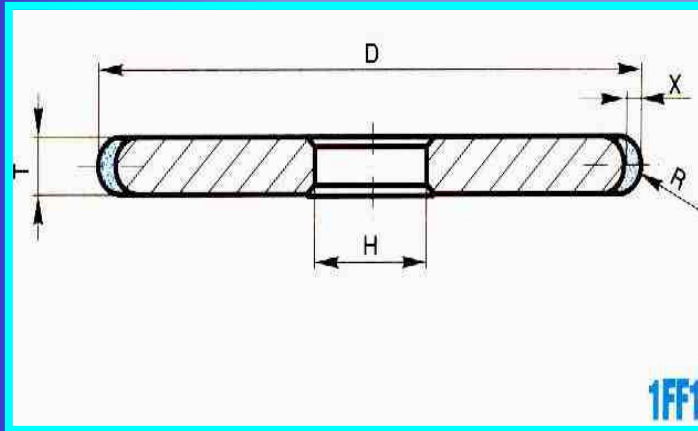

D	T	X	R	H*	D	T	X	R	H*
50				3	125				3
50				4	125				4
50				5	125				5
75				3	125				6
75	2R	2		4	125	2R	2		8
75				5	150				3
100				3	150				4
100				4	150				5
100				5	150				6
100				6	150				8

•resin bond

Example of order

Type **D - T - X - R - H**  
**1FF1 100 - 6 - 2 - 3 - 20** Grain size **D 64** Bond **R** Concentration **100**

H\* by request

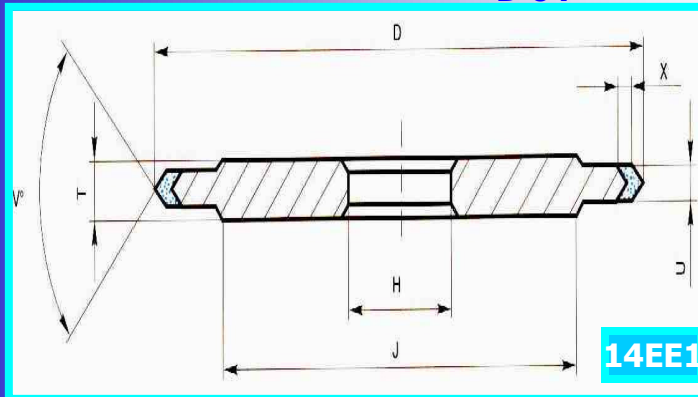

D	U	X	V°	H*	T	J
100	3				6	70
	4					
125	3				6	100
	4	6	35°			
150	3	5	45°		6	120
	4	4	60°			
175	3	3	90°		8	140
	4					
200	4				10	160
250	4				10	200

•resin bond

Example of order

Type **D - U - X - V° - H**  
**14EE1 100- 4 - 3 - 90°-20** Grain size **D 64** Bond **R** Concentration **100**



**1FF1**  
**14EE1**

# Extrahard materials tools for grinding and sharpening

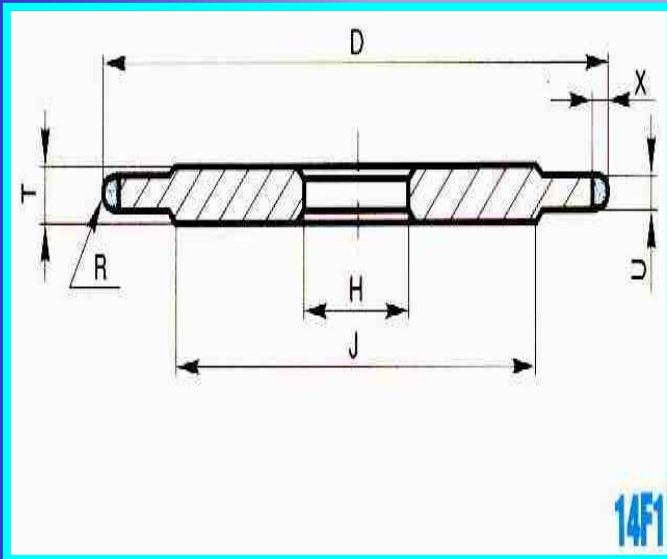

D	U	X	R	H*	T	J
50	2	2 ; 3 ; 4 ; 5	1	6	30	
50	3		1.5	6	30	
50	4		2	6	30	
75	2		1	6	50	
75	3		1.5	6	50	
75	4		2	6	50	
100	2		1	6	70	
100	3		1.5	6	70	
100	4		2	6	70	
125	2		1	6	100	
125	3		1.5	6	100	
125	4		2	6	100	
150	2		1	6	120	
150	3		1.5	6	120	
150	4		2	6	120	

H\* - by request

- resin bond

**14F1**



## Example of order

Type    D - U - X - R - H  
 14F1    100 - 3 - 2 - 1.5 - 20

Grain size    Bond    Concentration  
 D 64         R         100



# Extrahard materials tools for grinding and sharpening

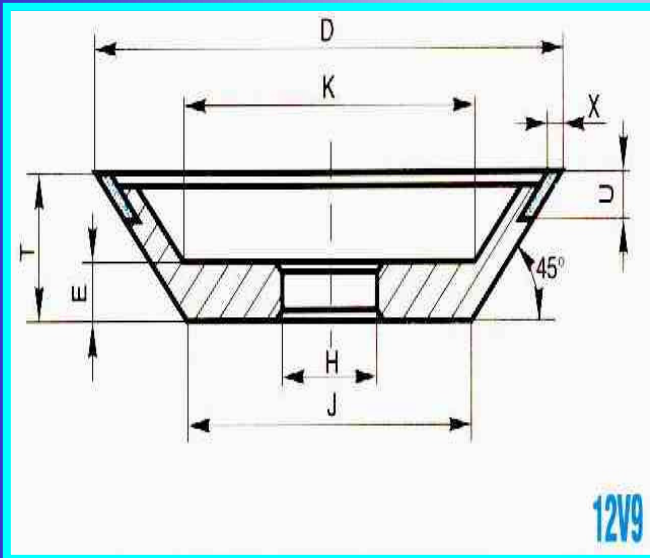

D	X	U	H*	T	E	K	J
50	2	6		20	10	20	20
75	2	6		20	10	45	35
75	3	6		20	10	45	35
100	2	6		20	10	65	60
100	3	6		20	10	65	60
125	2	6 ; 10		25	10	80	75
125	3	6 ; 10		25	10	80	75

•resin bond  
H\* - by request

**12V9**



## Example of order

Type D - X - U - H  
12V9 100 - 2 - 6 - 20

Grain size D 91    Bond R    Concentration 100



# Special diamond or cubic boron nitride grinding wheels with resin bond

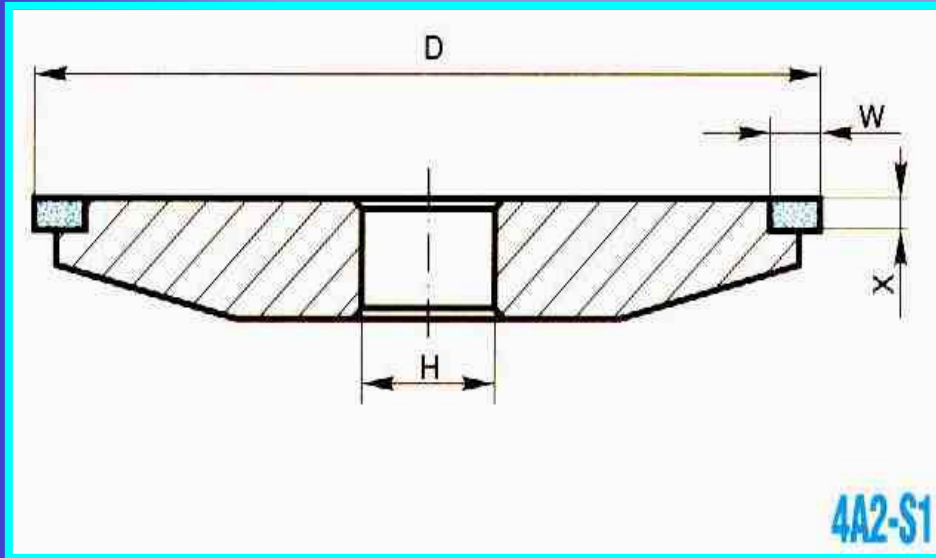

Specification: D -W-X-D 91 R 75

Machine tools: Vollmer-Biberach  
D= 100 ,125

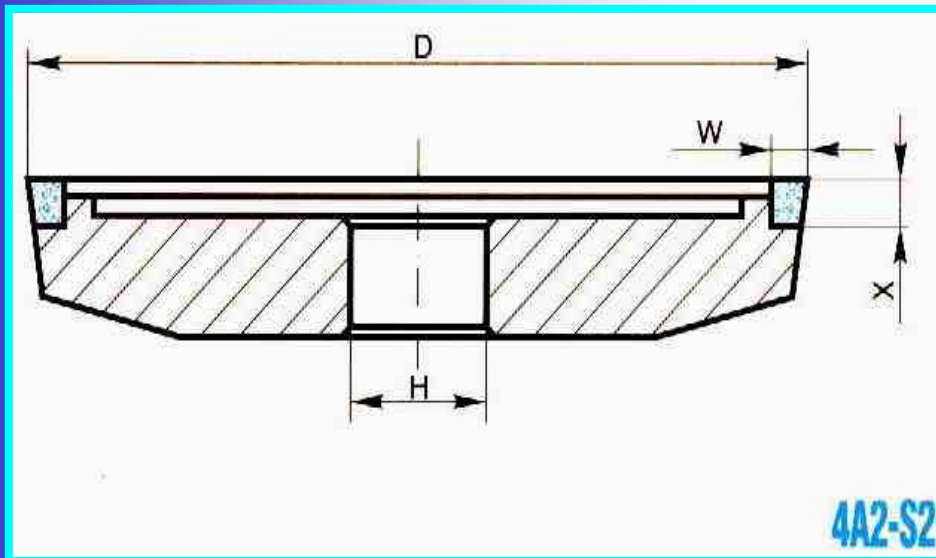

Specification: D -W-X-D 64 R 100

Machine tools: Vollmer-Biberach  
D= 100 ,125,150

4A2-S1/S2

(1)



# Special diamond or cubic boron nitride grinding wheels with resin bond

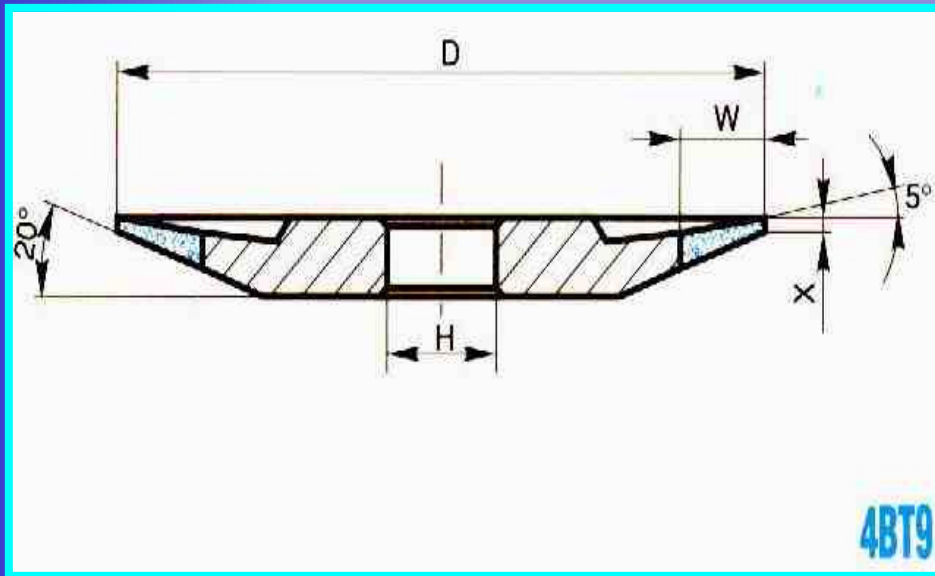

Specification: D -W-X-D64 R 100  
D= 75 ,100 ,125

4BT9  
6A2-S1

(2)

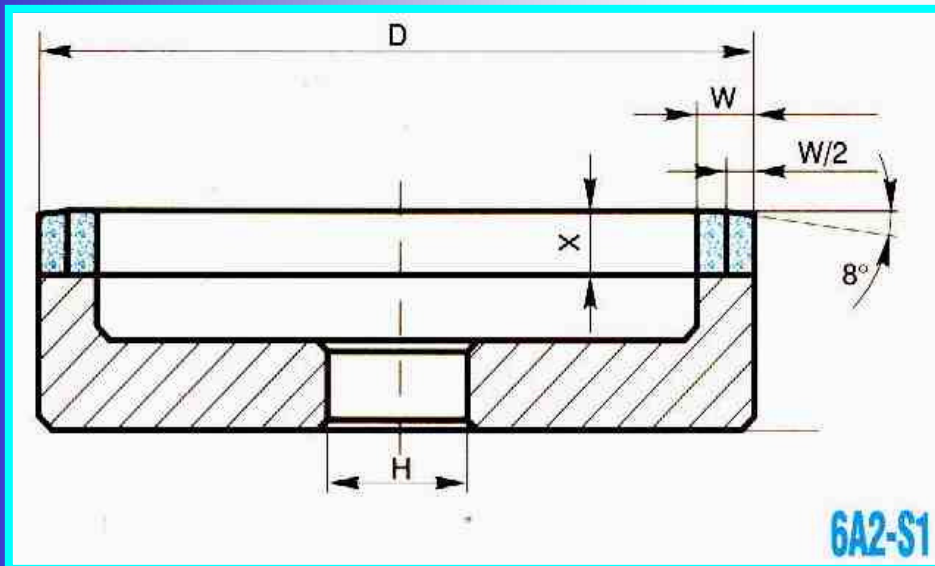

Specification: D -W-X-D126/D64  
R 100/R75

Machine tools: Vollmer-Biberach  
Vollmer-Dornhan  
Widma

D= 100 ,125,150  
2 grain sizes





# Special diamond or cubic boron nitride grinding wheels with resin bond

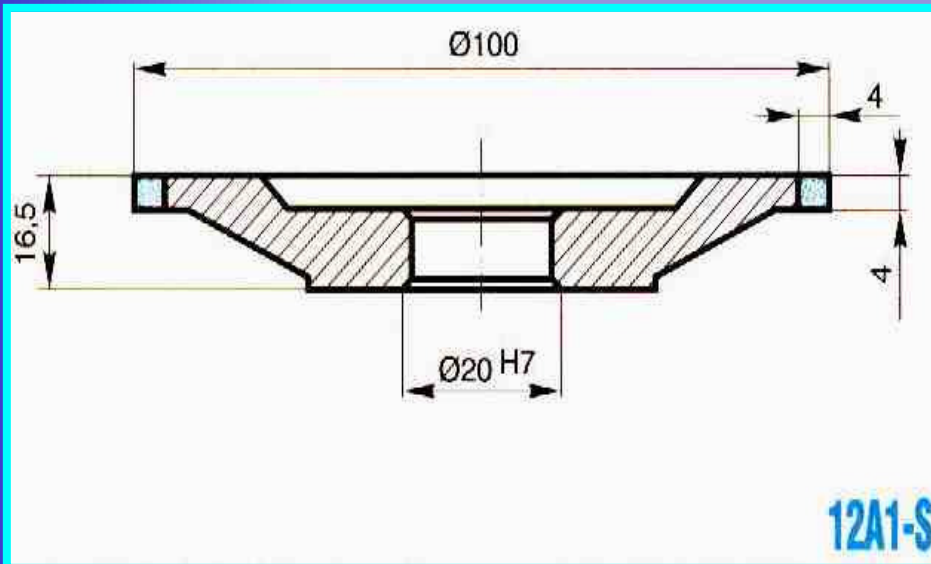

Specification: 100-4-4 D91 R75

Machine tools: Vollmer-Dornhan

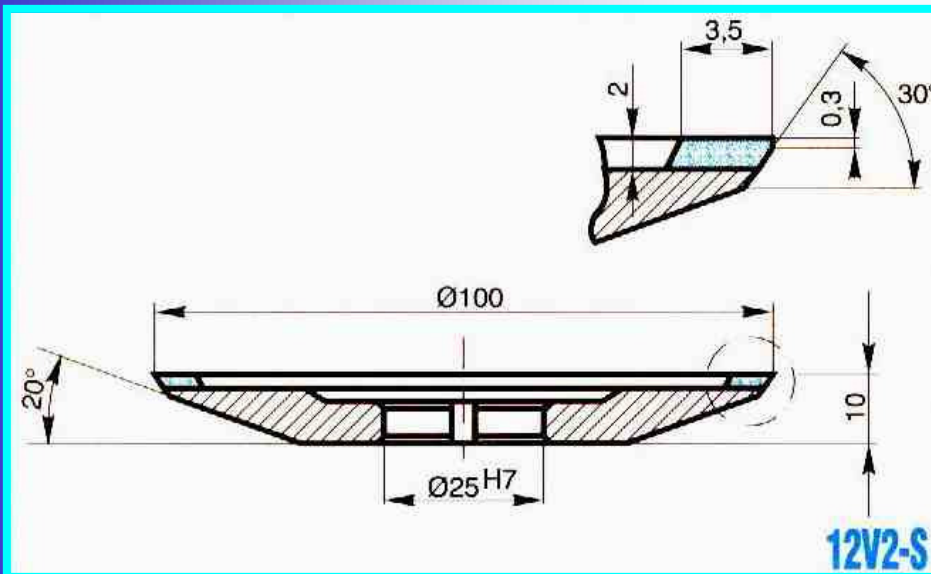

Specification: 100-4-2 D64 R 100

Machine tools: Vollmer-Dornhan

12A1-S  
12V2-S

(3)

DIATEH

# Special diamond or cubic boron nitride grinding wheels with resin bond

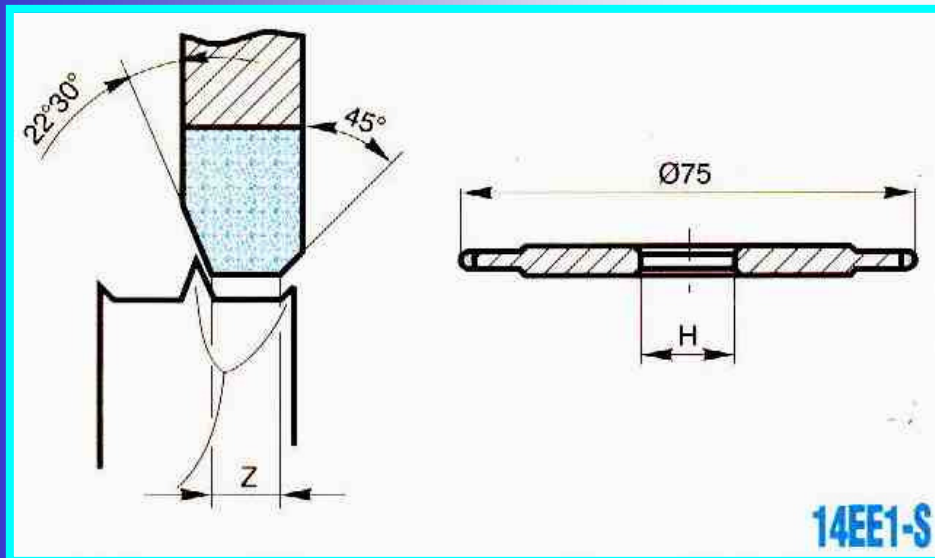
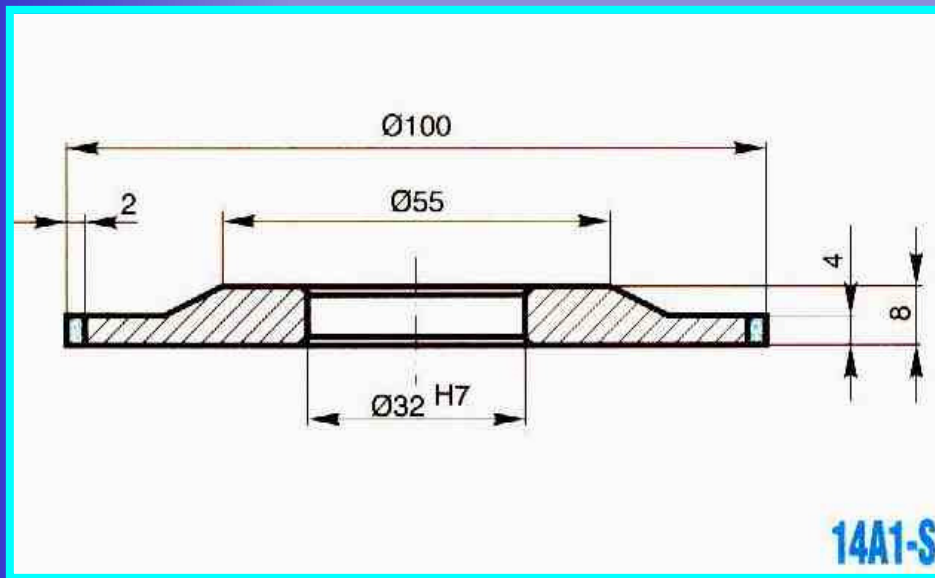

14A1-S  
14 EE1-S

(4)

Specification: 100-4-2 D76 R75

Machine tools: Vollmer-Biberach

Specification:

75 -4.5-6 D 64 R75

75 - 5 - 6 D 64 R 75

75 -6 - 6 D 64 R 75

